

# Mind the Gap : Accommodating Neurodiversity in Singapore's MRT

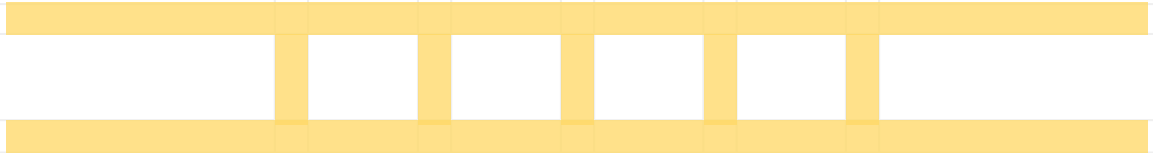

Author : Ishmam Ahmed (Yale-NUS College)

Advisor : Professor Jane Margaret Jacobs (Yale-NUS College)

---

# Mind the Gap : Accommodating Neurodiversity in Singapore's MRT

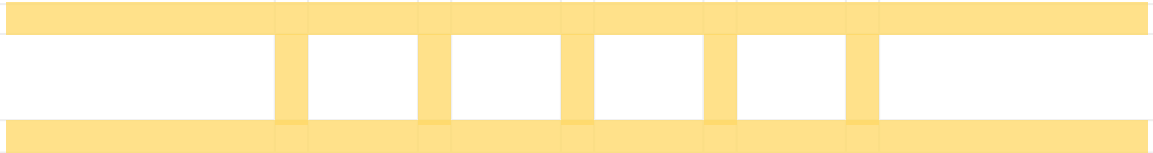

Author : Ishmam Ahmed (Yale-NUS College)

Advisor : Professor Jane Margaret Jacobs (Yale-NUS College)

---

Current : Research Associate, DesCartes Program

The French National Center for Scientific Research (CNRS@CREATE)

# Focus

## Neurodiversity

ASD

ADHD

“

Neurodiversity, or Neurodivergence, refers to variations in the human brain and cognition, for instance in sociability, information processing, navigation, attention, sensory tolerance, and other mental functions.

”

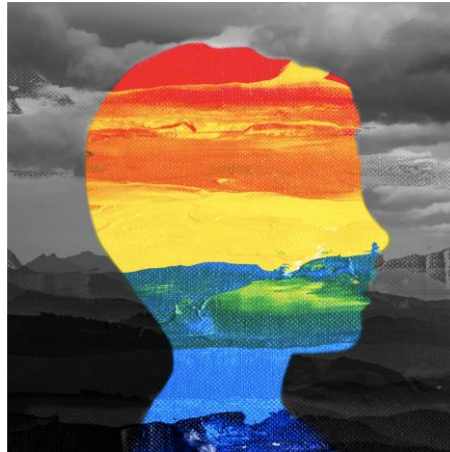

# Focus

## Neurodiversity

ASD

ADHD

“

Autism Spectrum Disorder (ASD) is a neurodevelopmental condition affecting communication, social interaction, and environmental experience, involving repetitive behaviors, focused interests, and differences in sensory processing.

”

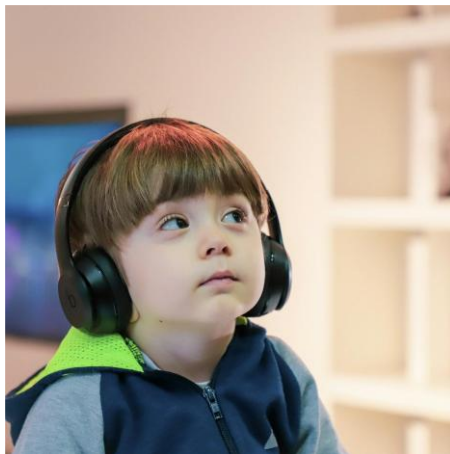

# Focus

## Neurodiversity

ASD

ADHD

“

Attention-Deficit/Hyperactivity Disorder (ADHD) refers to a neurodevelopmental condition affecting an individual's attention regulation, executive functioning, impulse control, response to stimuli, and levels of hyperactivity.

”



# Methods



## Interviews

---

Carers of ASD Individuals

Individuals with ADHD

Experts

## Surveys

---

Individuals with ADHD

## Field Work

---

Route Mapping

Sensory Mapping

Location : Outram Park

# Methods

## Interviews

Carers of ASD Individuals

Individuals with ADHD

Experts

## Surveys

Individuals with ADHD

## Field Work

Route Mapping

Sensory Mapping

Location : Outram Park



# Methods

## Interviews

- Carers of ASD Individuals
- Individuals with ADHD
- Experts



## Surveys

- Individuals with ADHD

## Field Work

- Route Mapping
- Sensory Mapping
- Location : Outram Park

# Methods

---

## Interviews

---

Carers of ASD Individuals

Individuals with ADHD

Experts

## Surveys

---

Individuals with ADHD

## Field Work

---

Route Mapping

Sensory Mapping

Location : Outram Park



# Methods

## Interviews

- Carers of ASD Individuals
- Individuals with ADHD
- Experts

## Surveys

Individuals with ADHD

## Field Work

- Route Mapping
- Sensory Mapping
- Location : Outram Park

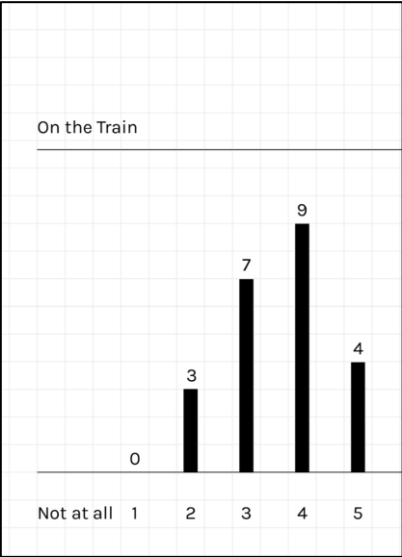

# Methods

## Interviews

Carers of ASD Individuals  
Individuals with ADHD  
Experts

## Surveys

Individuals with ADHD

## Field Work

- ▶ Route Mapping
- Sensory Mapping
- Location : Outram Park

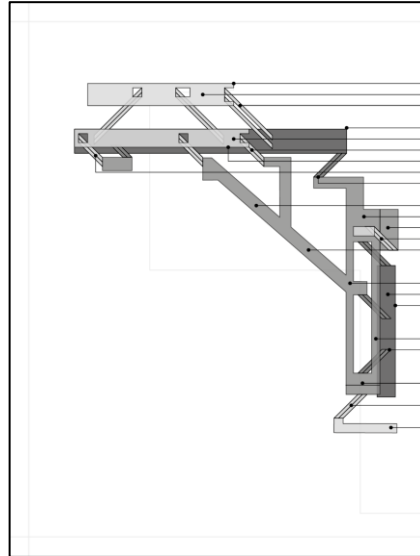

# Methods

## Interviews

- Carers of ASD Individuals
- Individuals with ADHD
- Experts

## Surveys

- Individuals with ADHD

## Field Work

- Route Mapping
- Sensory Mapping
- Location : Outram Park

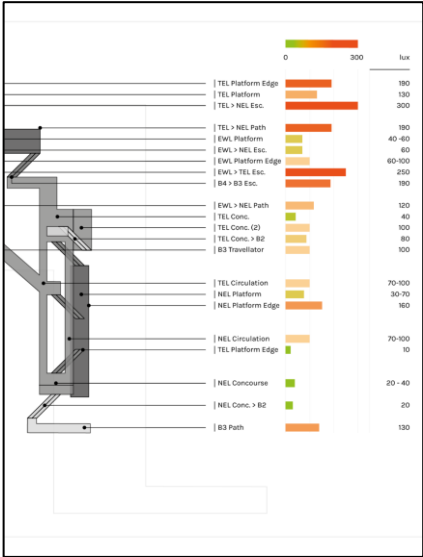

# Literature

## Areas

Fields

Sub-fields

Gaps

Capstone

Draws from

Contributes to

Urban Studies

Architecture

Psychology

# Literature



## Areas



Fields

Sub-fields

Gaps

Capstone

Draws from

Contributes to

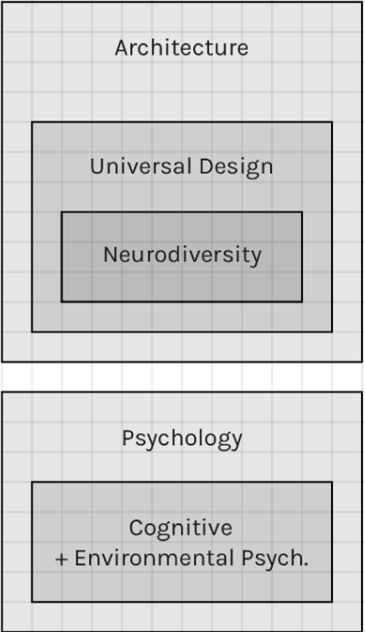
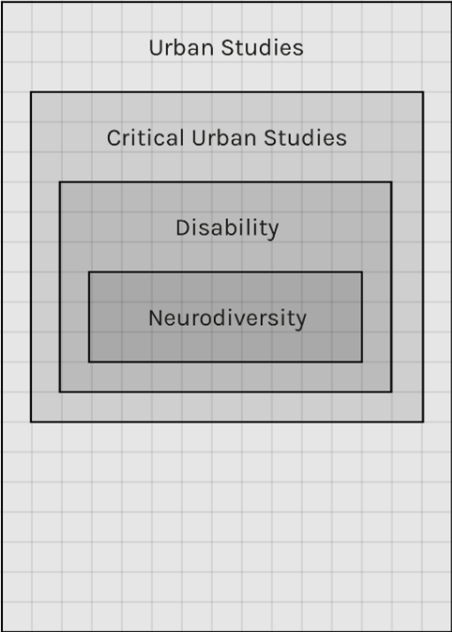

# Literature

## Areas

- Fields
- Sub-fields
- Gaps
- Capstone
- Draws from
- Contributes to

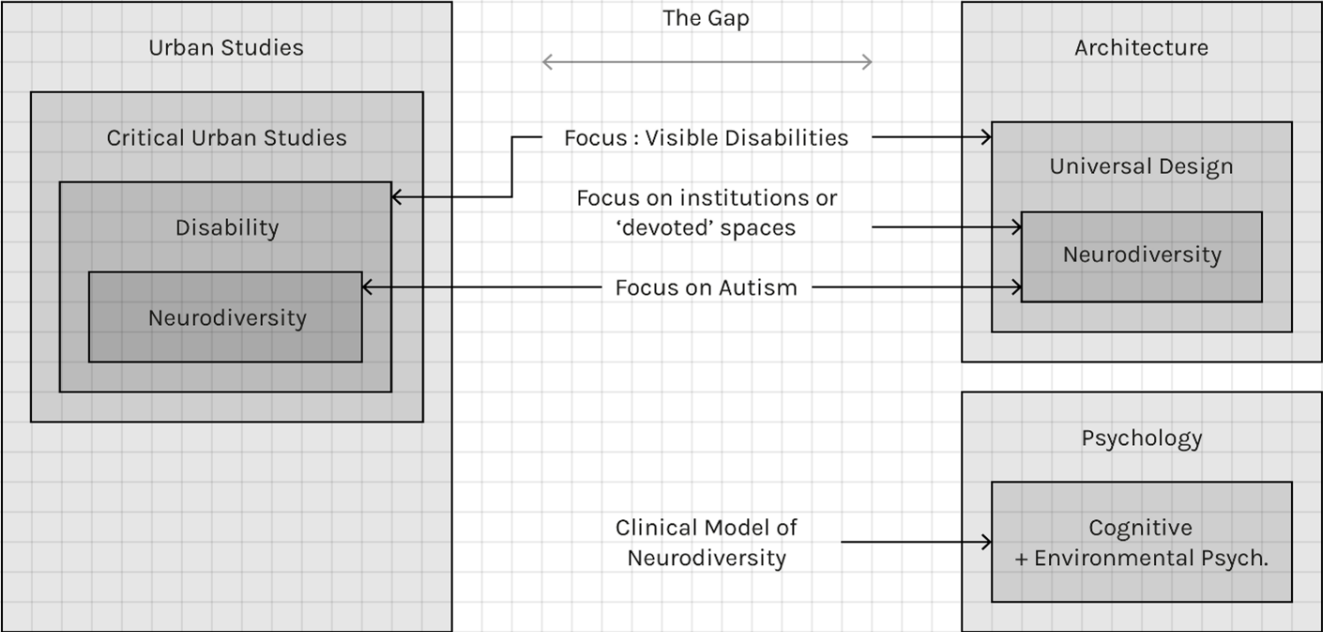

# Literature



## Areas



- Fields
- Sub-fields
- Gaps
- Capstone
- Draws from
- Contributes to

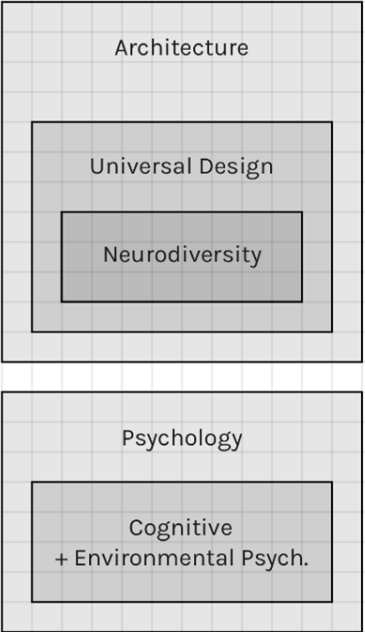
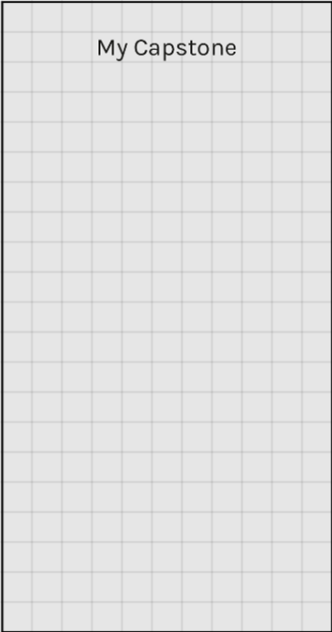
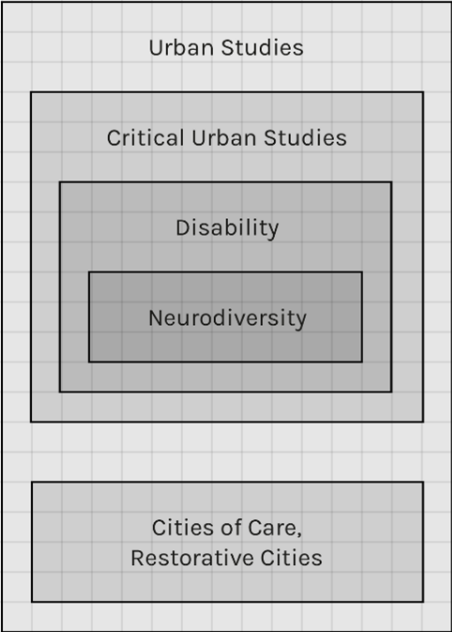

# Literature



## Areas



- Fields
- Sub-fields
- Gaps
- Capstone
- Draws from
- Contributes to

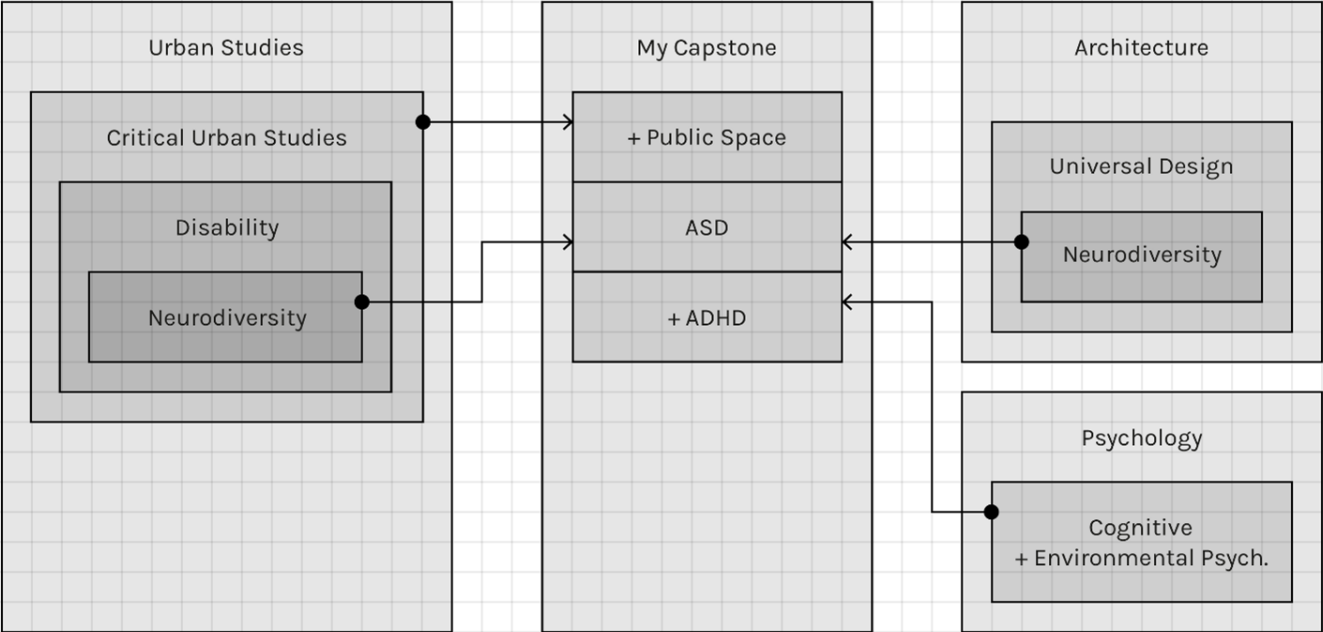

# Literature



## Areas



- Fields
- Sub-fields
- Gaps
- Capstone
- Draws from
- Contributes to

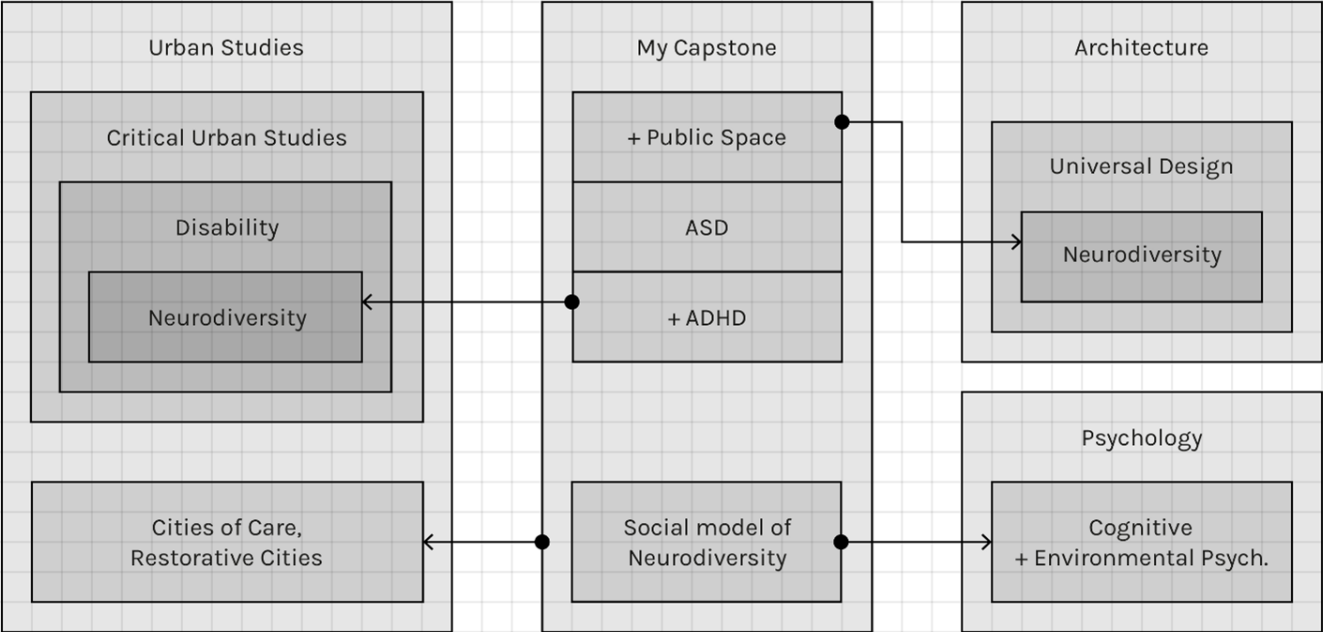

# Findings

Sensory

Wayfinding

Social

# Sensory

---

## Needs

---

Sensitive Acoustics

Sensitive, Glare-free Lighting

Sensory Transitions

## Gaps

---

'Overlit' Stations

Inconsistent Transitions

Security & Facial Recognition

## Proposals

---

Sensitive Lighting

Sensor-assisted Transitions

Circadian Lighting

# Sensory

## Needs

### Sensitive Acoustics

Sensitive, Glare-free Lighting

Sensory Transitions

## Gaps

'Overlit' Stations

Inconsistent Transitions

Security & Facial Recognition

## Proposals

Sensitive Lighting

Sensor-assisted Transitions

Circadian Lighting

“

The announcement noises at every stop could be a gentler thing. Instead of like, you know, when you arrive at a station, it blurts out loud beeps.

”

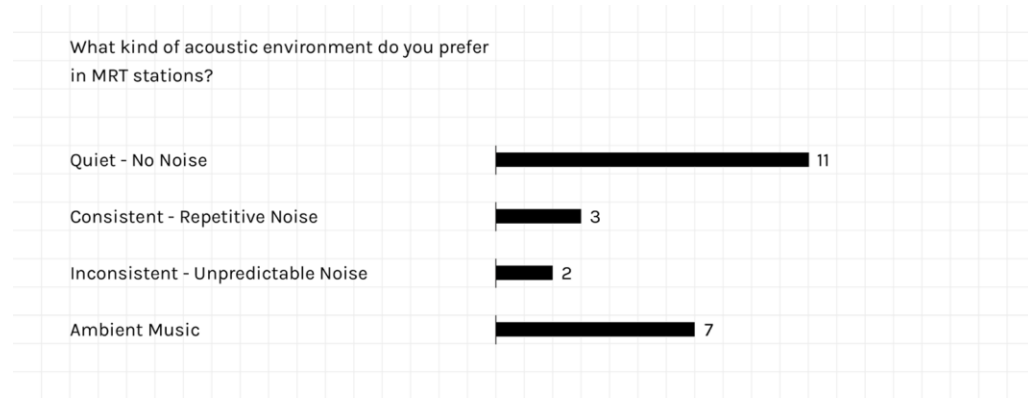

# Sensory

## Needs

Sensitive Acoustics

Sensitive, Glare-free Lighting

Sensory Transitions

## Gaps

'Overlit' Stations

Inconsistent Transitions

Security & Facial Recognition

## Proposals

Sensitive Lighting

Sensor-assisted Transitions

Circadian Lighting

“

The lights at the boarding gates. I hate it so much. It gives me a headache. It stresses me out.

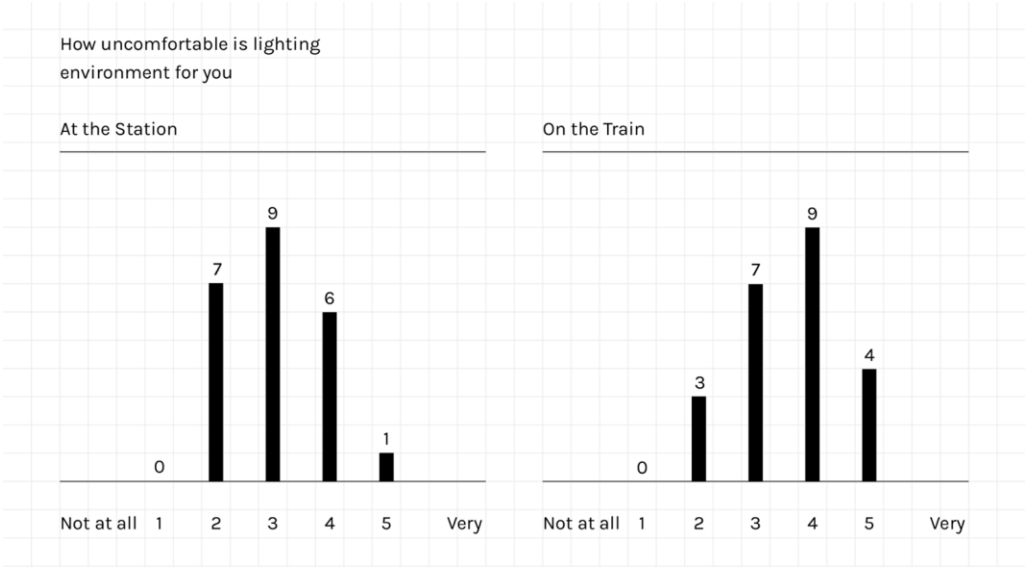

# Sensory

## Needs

Sensitive Acoustics

Sensitive, Glare-free Lighting

Sensory Transitions

## Gaps

'Overlit' Stations

Inconsistent Transitions

Security & Facial Recognition

## Proposals

Sensitive Lighting

Sensor-assisted Transitions

Circadian Lighting

“

I feel that the most distressing part of an MRT station is the escalators. Yeah, it's right there at your eye and it's, and it's bright, dark, bright, dark, like that.

”



# Sensory

## Needs

Sensitive Acoustics

Sensitive, Glare-free Lighting

Sensory Transitions

## Gaps

'Overlit' Stations

Inconsistent Transitions

Security & Facial Recognition

## Proposals

Sensitive Lighting

Sensor-assisted Transitions

Circadian Lighting

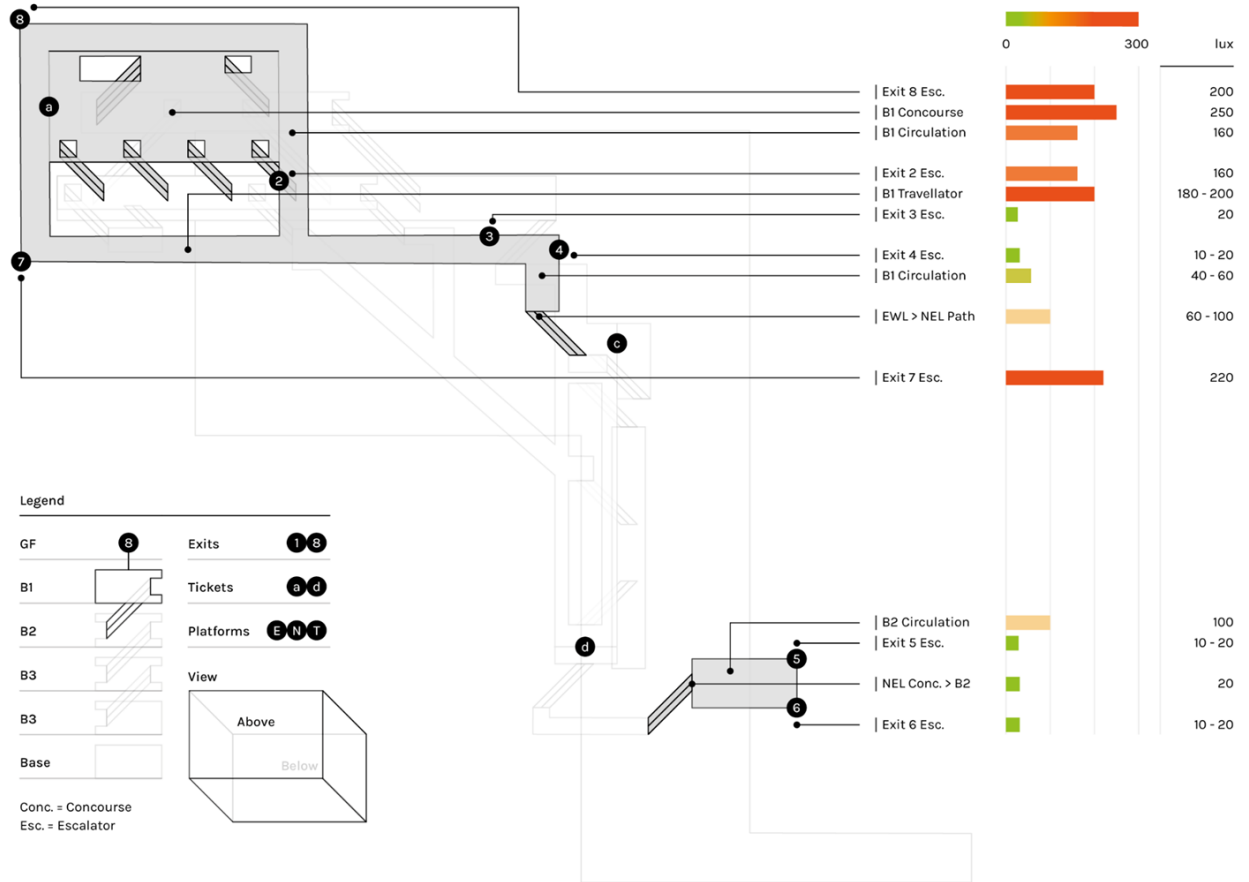

# Sensory

## Needs

Sensitive Acoustics

Sensitive, Glare-free Lighting

Sensory Transitions

## Gaps

'Overlit' Stations

Inconsistent Transitions

Security & Facial Recognition

## Proposals

Sensitive Lighting

Sensor-assisted Transitions

Circadian Lighting

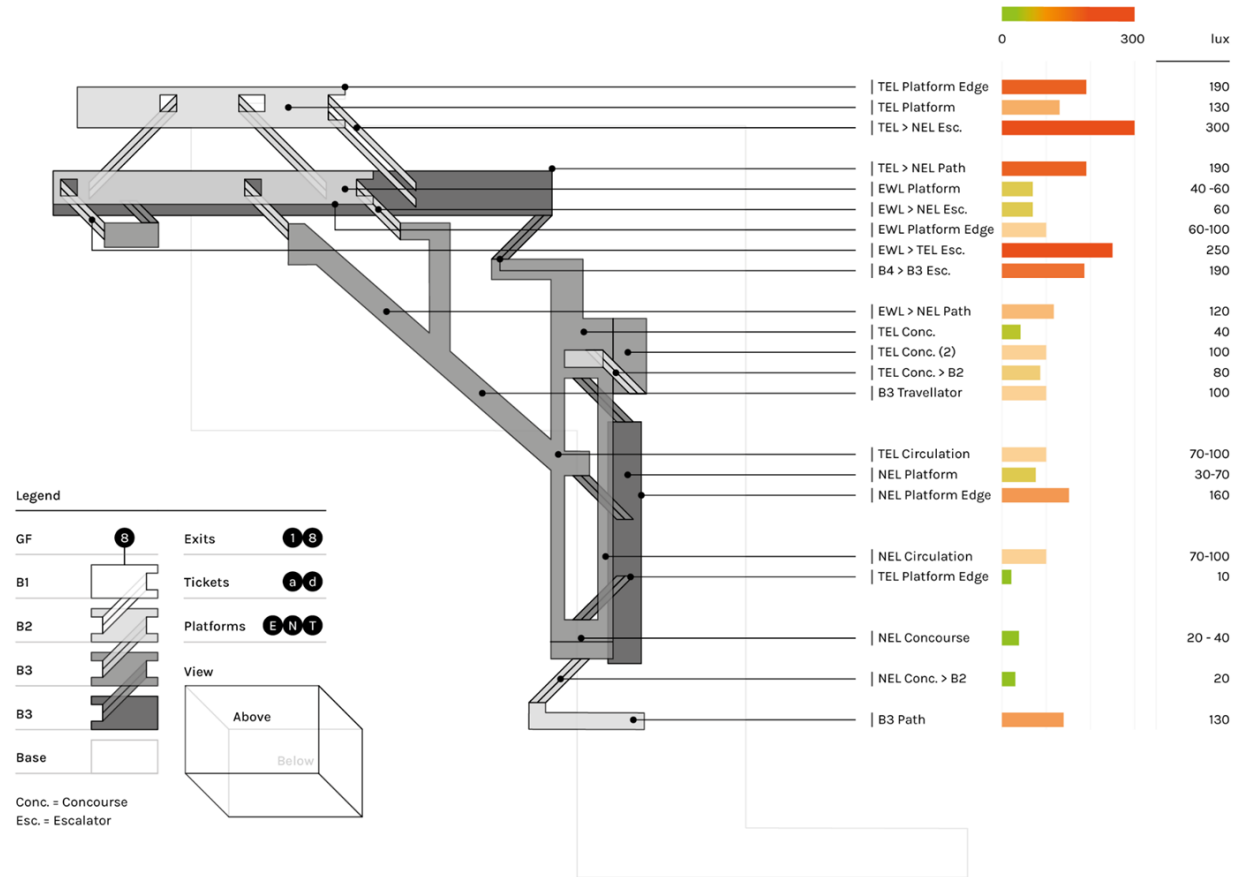

# Sensory



## Needs



- Sensitive Acoustics
- Sensitive, Glare-free Lighting
- Sensory Transitions

## Gaps



- 'Overlit' Stations
- Inconsistent Transitions
- Security & Facial Recognition

## Proposals



- Sensitive Lighting
- Sensor-assisted Transitions
- Circadian Lighting

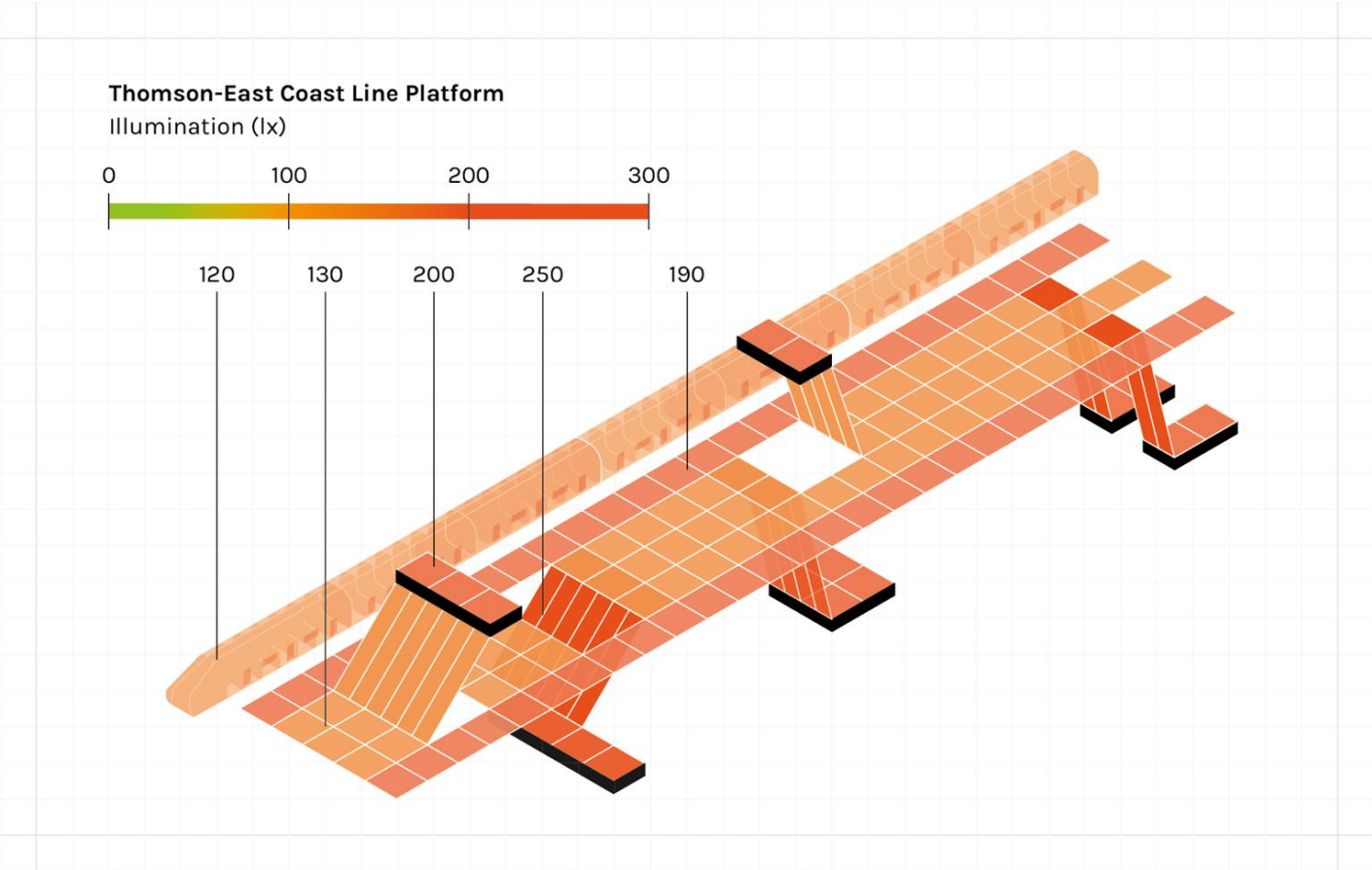

# Sensory

## Needs

- Sensitive Acoustics
- Sensitive, Glare-free Lighting
- Sensory Transitions

## Gaps

- 'Overlit' Stations
- Inconsistent Transitions
- Security & Facial Recognition

## Proposals

- Sensitive Lighting
- Sensor-assisted Transitions
- Circadian Lighting

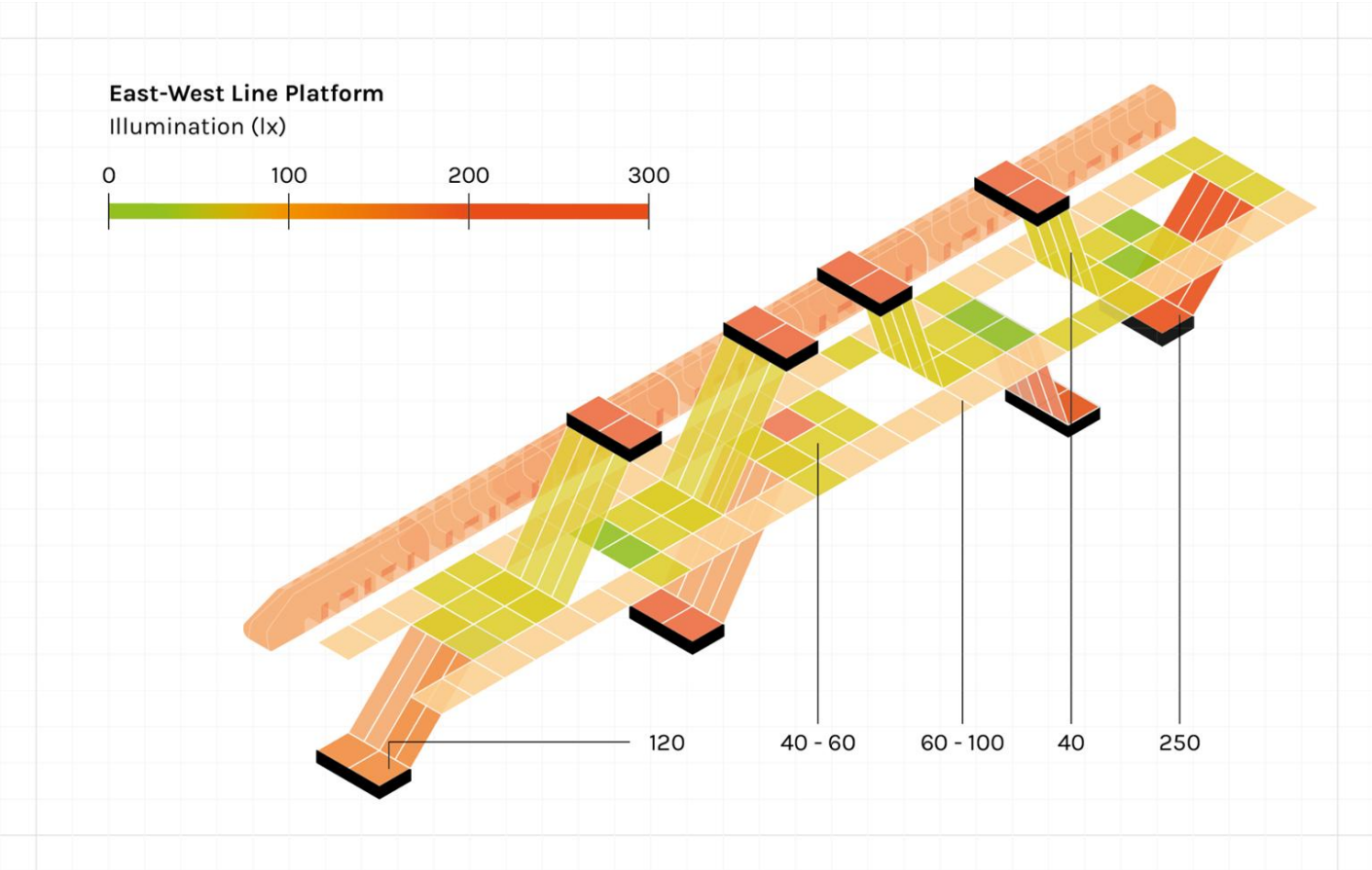

# Sensory

## Needs

Sensitive Acoustics

Sensitive, Glare-free Lighting

Sensory Transitions

## Gaps

'Overlit' Stations

Inconsistent Transitions

Security & Facial Recognition

## Proposals

Sensitive Lighting

Sensor-assisted Transitions

Circadian Lighting

### Outram Park Exits

Illumination (lx)



Exit 3 - 6

Exits 1 & 2

Exit 7 & 8

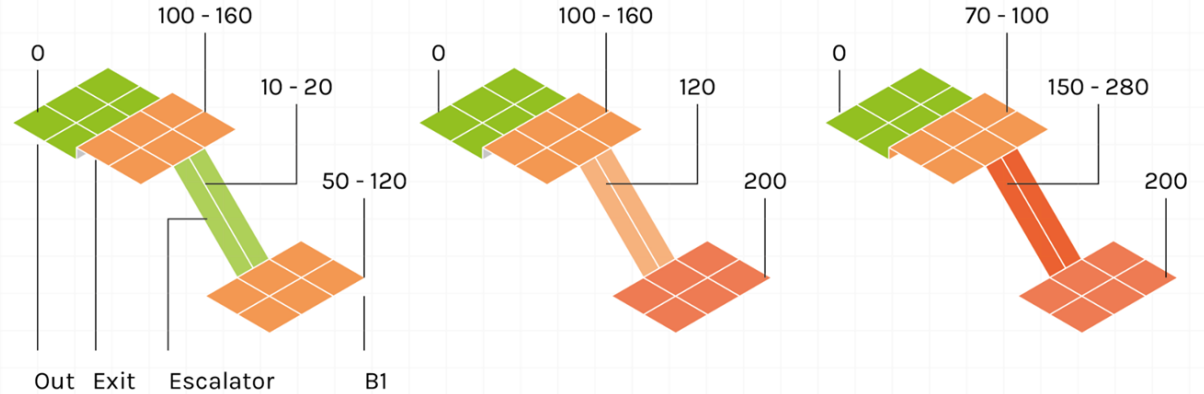

# Sensory

## Needs

Sensitive Acoustics

Sensitive, Glare-free Lighting

Sensory Transitions

## Gaps

'Overlit' Stations

Inconsistent Transitions

Security & Facial Recognition

## Proposals

Sensitive Lighting

Sensor-assisted Transitions

Circadian Lighting



Lights at North-East Line Platform (Outram)



Lights at Thomson-East Coast Line Platform (Outram)

# Sensory

## Needs

Sensitive Acoustics

Sensitive, Glare-free Lighting

Sensory Transitions

## Gaps

'Overlit' Stations

Inconsistent Transitions

Security & Facial Recognition

## Proposals

Sensitive Lighting

Sensor-assisted Transitions

Circadian Lighting



Lights at TEL-NEL Linway in  
Basement 4 (Outram)



Lights at Orchard Station Exit 4

# Sensory

## Needs

Sensitive Acoustics

Sensitive, Glare-free Lighting

Sensory Transitions

## Gaps

'Overlit' Stations

Inconsistent Transitions

Security & Facial Recognition

## Proposals

Sensitive Lighting

Sensor-assisted Transitions

Circadian Lighting

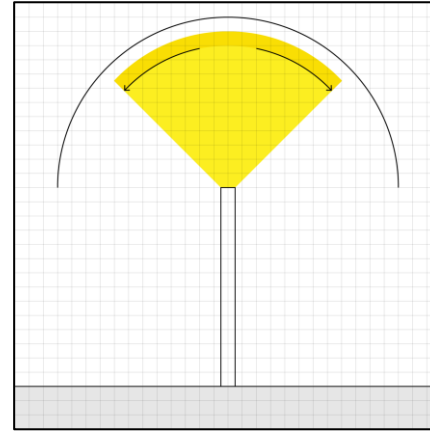
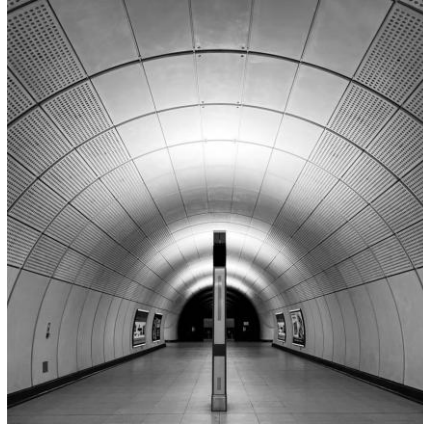

Lighting 'Totems' at London's New Elizabeth Line (2022)

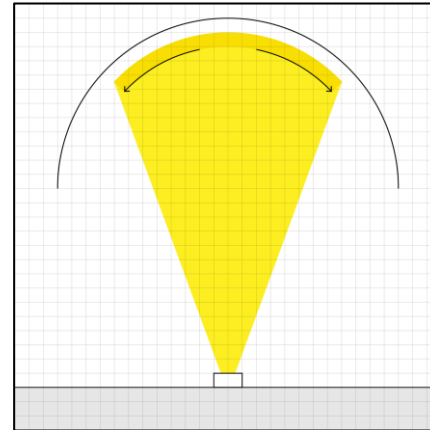
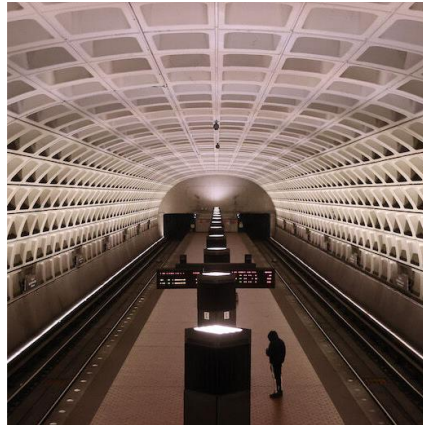

Lighting Totems and Ground Lights at DC Metro (1976)

# Sensory

## Needs

- Sensitive Acoustics
- Sensitive, Glare-free Lighting
- Sensory Transitions

## Gaps

- 'Overlit' Stations
- Inconsistent Transitions
- Security & Facial Recognition

## Proposals

- Sensitive Lighting
- Sensor-assisted Transitions
- Circadian Lighting

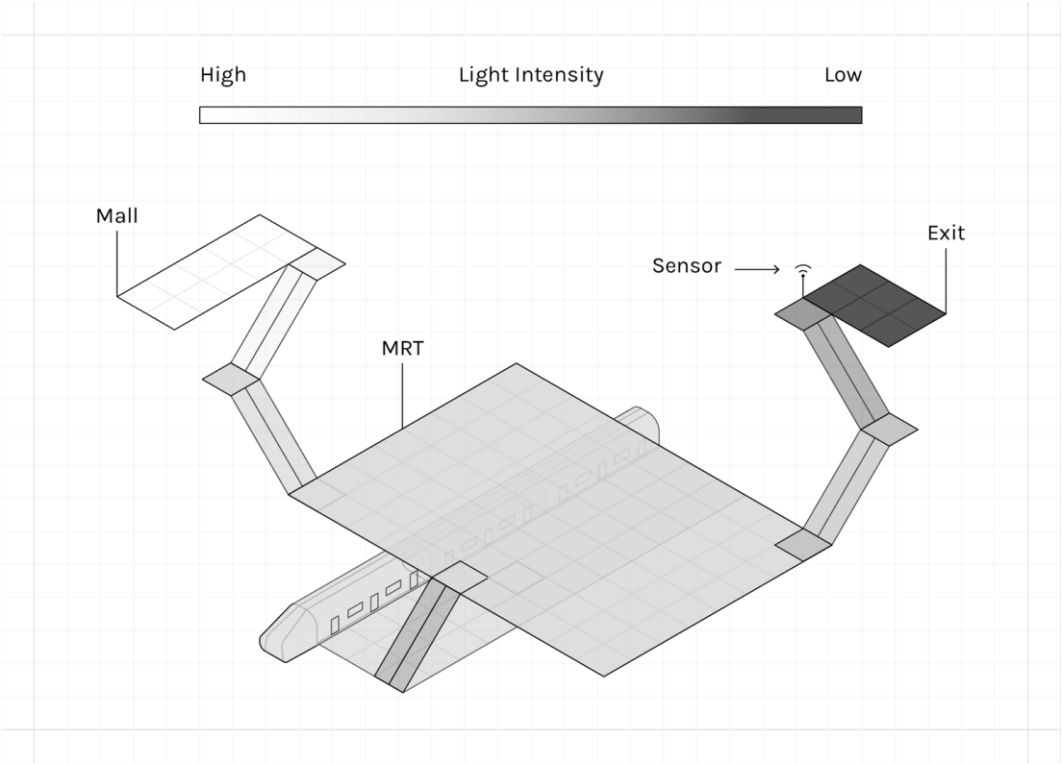

# Sensory

## Needs

- Sensitive Acoustics
- Sensitive, Glare-free Lighting
- Sensory Transitions

## Gaps

- 'Overlit' Stations
- Inconsistent Transitions
- Security & Facial Recognition

## Proposals

- Sensitive Lighting
- Sensor-assisted Transitions
- Circadian Lighting

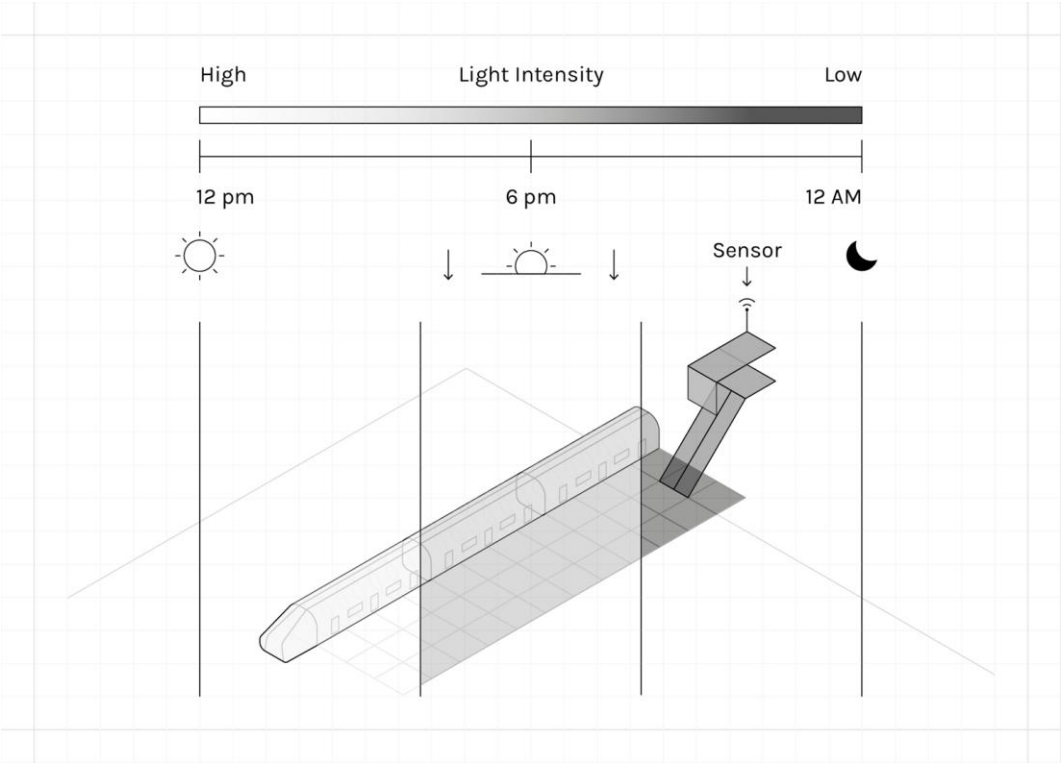

# Wayfinding

---

## Needs

---

Simple/Intuitive Directions

Minimal Decision making

Consistency

## Gaps

---

Lack of Spatial Organisation

Visual Clutter

'Privatised Public Space'

## Proposals

---

ND Wayfinding Approach

Same route despite Expansion

Minimal Decision making

# Wayfinding

---

## Needs

---

Simple/Intuitive Directions

Minimal Decision making

Consistency

## Gaps

---

Lack of Spatial Organisation

Visual Clutter

'Privatised Public Space'

## Proposals

---

ND Wayfinding Approach

Same route despite Expansion

Minimal Decision making

“

Signboards with words don't mean anything to him ... what I found easy is to find simple things like color codes, numbers ... something visually representative

“

It's so much information to process visually at one point ... all I need to know is where I'm going (about the animated maps)

# Wayfinding

---

## Needs

---

Simple/Intuitive Directions

Minimal Decision making

Consistency

## Gaps

---

Lack of Spatial Organisation

Visual Clutter

'Privatised Public Space'

## Proposals

---

ND Wayfinding Approach

Same route despite Expansion

Minimal Decision making

“

At that moment (in the train) I don't need the information about the station plan. I'm already so anxious about just getting off at the right time (Adult with ADHD)

“

I pick routes where I have to switch (trains, buses) the least ... sometimes I will pick longer routes if that means I'll be making less decisions (Adult with ADHD)

# Wayfinding

---

## Needs

---

Simple/Intuitive Directions

Minimal Decision making

Consistency

## Gaps

---

Lack of Spatial Organisation

Visual Clutter

'Privatised Public Space'

## Proposals

---

ND Wayfinding Approach

Same route despite Expansion

Minimal Decision making

“

What really helps is preparing them (their child with ASD) for what's coming up, or going to the station or what's going to happen

“

I noticed that finding the board with the station exits is easier at some stations, but at others I have to go hunt for it. (Caregiver of child with ASD)

“

You have a sign that says J up ahead, but when you go up ahead it says A up ahead. ... then you walk like five minutes ahead and you finally see J. (Adult with ADHD)

# Wayfinding

## Needs

Simple/Intuitive Directions

Minimal Decision making

Consistency

## Gaps

Lack of Spatial Organisation

Visual Clutter

'Privatised Public Space'

## Proposals

ND Wayfinding Approach

Same route despite Expansion

Minimal Decision making

In terms of Spatial Design, I prefer MRT stations that are -

Predictable  
(Has similar spatial design/layout; i.e. Circle Line)

15

Unique  
(Has distinct spatial design, easily differentiable)

8

# Wayfinding

## Needs

- Simple/Intuitive Directions
- Minimal Decision making
- Consistency

## Gaps

Lack of Spatial Organisation

- Visual Clutter
- 'Privatised Public Space'

## Proposals

- ND Wayfinding Approach
- Same route despite Expansion
- Minimal Decision making

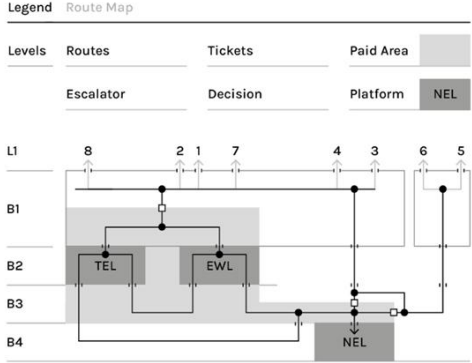
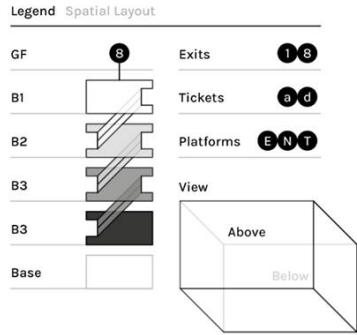
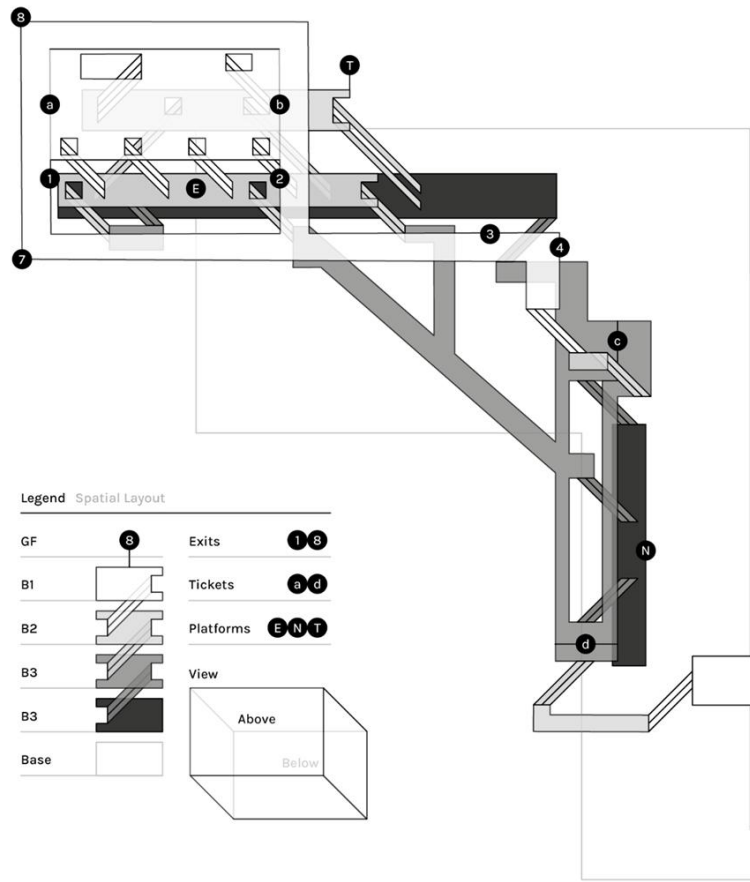

# Wayfinding

## Needs

- Simple/Intuitive Directions
- Minimal Decision making
- Consistency

## Gaps

- Lack of Spatial Organisation
- Visual Clutter
- 'Privatised Public Space'

## Proposals

- ND Wayfinding Approach
- Same route despite Expansion
- Minimal Decision making

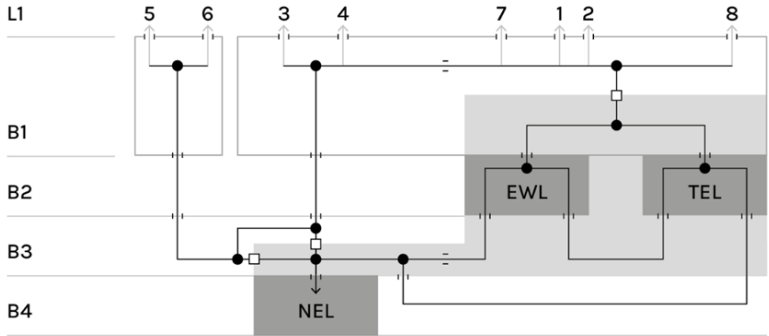
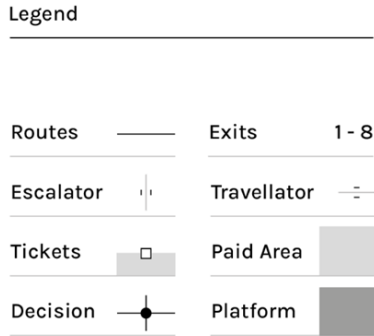

# Wayfinding

## Needs

Simple/Intuitive Directions

Minimal Decision making

Consistency

## Gaps

Lack of Spatial Organisation

Visual Clutter

'Privatised Public Space'

## Proposals

ND Wayfinding Approach

Same route despite Expansion

Minimal Decision making

### East-West Line Platform Signage

-  Way out
-  To TEL
-  To NEL
-  Way out (primary)  
 & TEL (secondary)

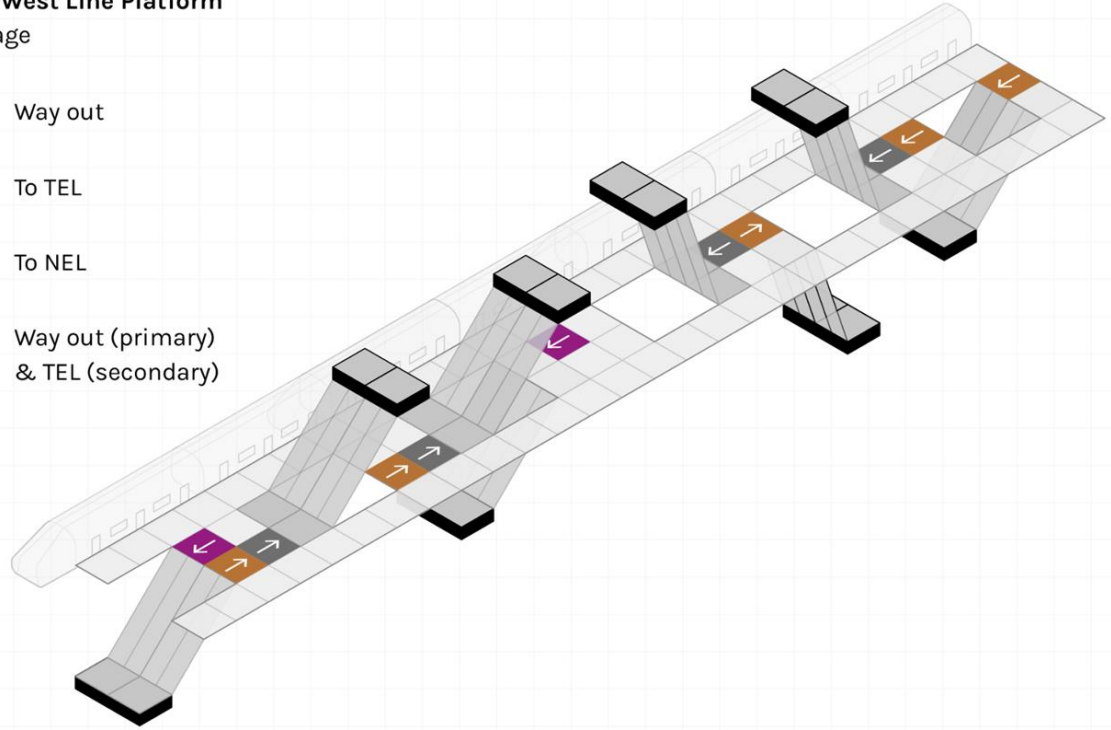

# Wayfinding

## Needs

Simple/Intuitive Directions

Minimal Decision making

Consistency

## Gaps

Lack of Spatial Organisation

Visual Clutter

▶ 'Privatised Public Space'

## Proposals

ND Wayfinding Approach

Same route despite Expansion

Minimal Decision making

“

... I just want to get in and out of them.

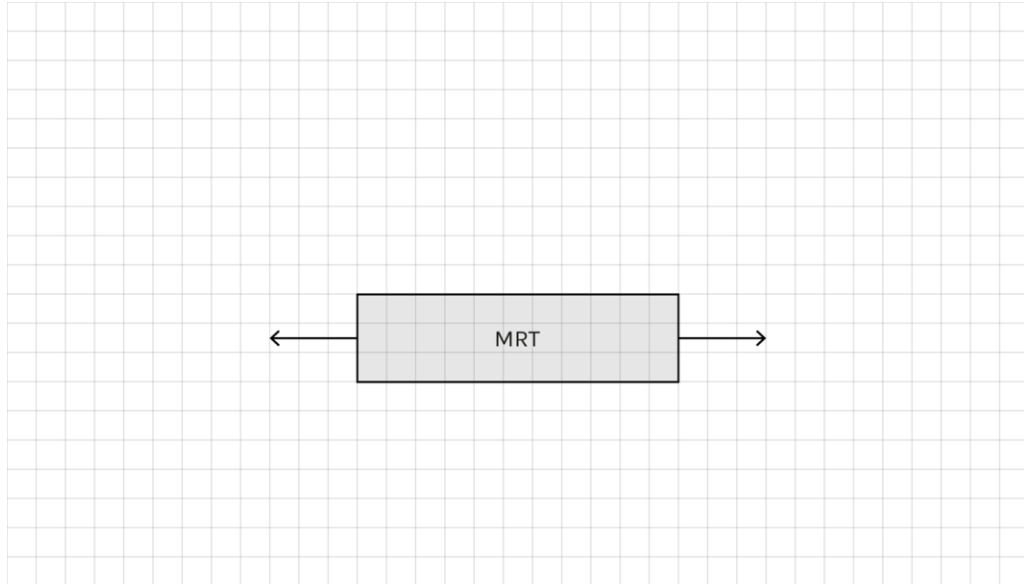

# Wayfinding

## Needs

Simple/Intuitive Directions

Minimal Decision making

Consistency

## Gaps

Lack of Spatial Organisation

Visual Clutter

‘Privatised Public Space’

## Proposals

ND Wayfinding Approach

Same route despite Expansion

Minimal Decision making

“

I hate the ones that have a whole shopping mall next to them. I feel like that's not the point (of the station). I just want to get in and out of them.

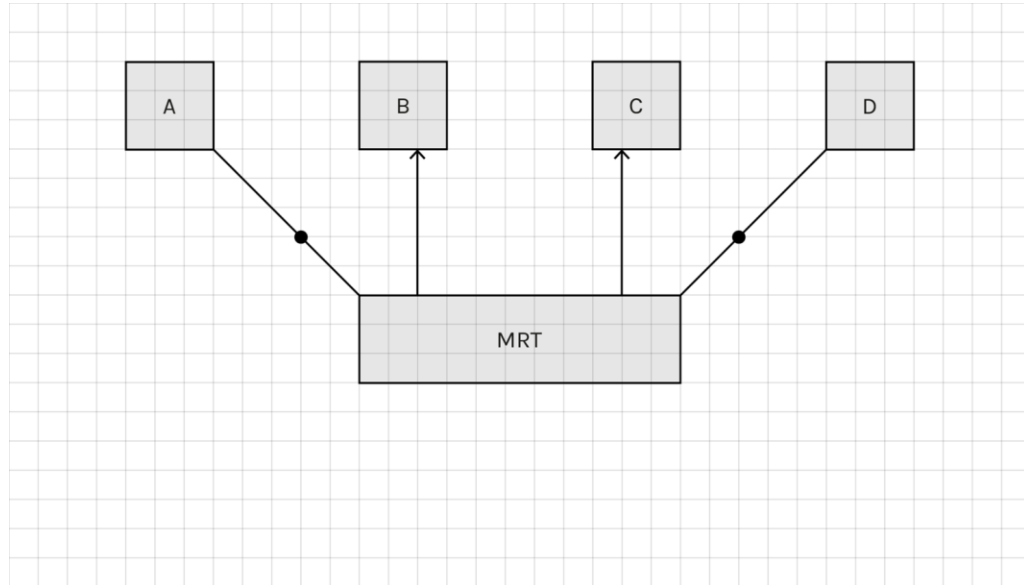

# Wayfinding

## Needs

Simple/Intuitive Directions

Minimal Decision making

Consistency

## Gaps

Lack of Spatial Organisation

Visual Clutter

'Privatised Public Space'

## Proposals

ND Wayfinding Approach

Same route despite Expansion

Minimal Decision making

“

I hate the ones that have a whole shopping mall next to them. I feel like that's not the point (of the station). I just want to get in and out of them.

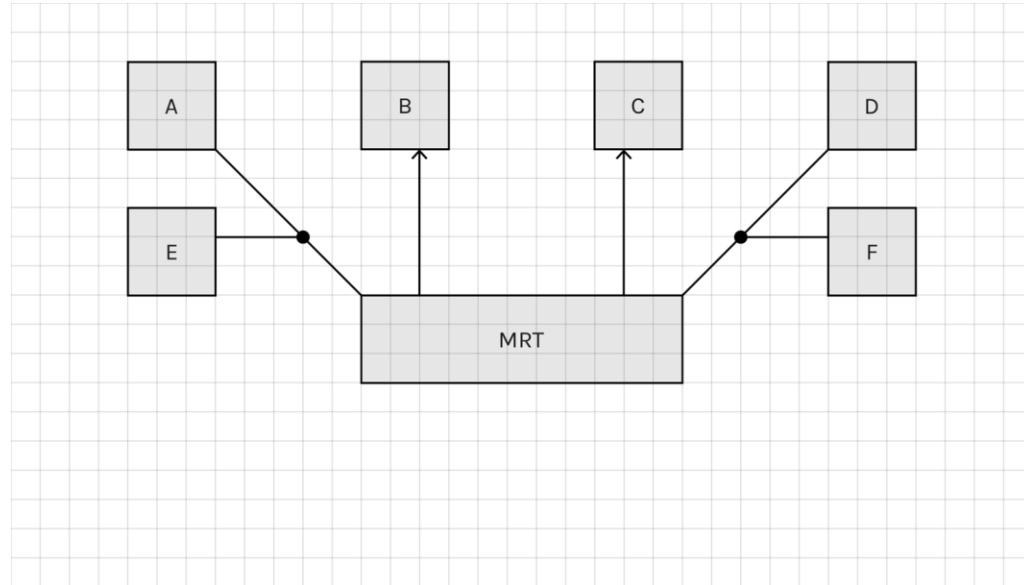

# Wayfinding

## Needs

Simple/Intuitive Directions

Minimal Decision making

Consistency

## Gaps

Lack of Spatial Organisation

Visual Clutter

'Privatised Public Space'

## Proposals

ND Wayfinding Approach

Same route despite Expansion

Minimal Decision making

“

I hate the ones that have a whole shopping mall next to them. I feel like that's not the point (of the station). I just want to get in and out of them.

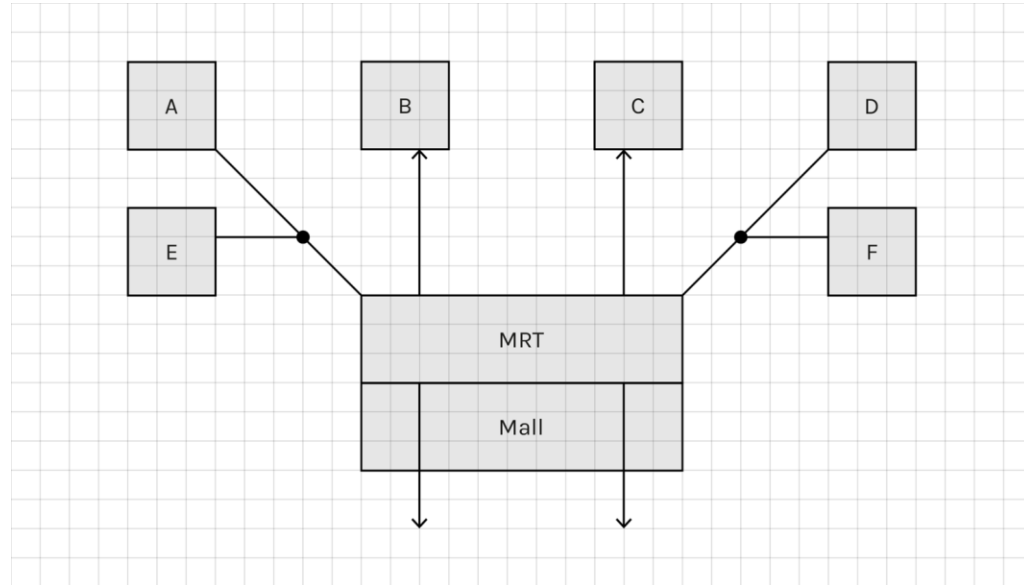

# Wayfinding

## Needs

Simple/Intuitive Directions

Minimal Decision making

Consistency

## Gaps

Lack of Spatial Organisation

Visual Clutter

'Privatised Public Space'

## Proposals

ND Wayfinding Approach

Same route despite Expansion

Minimal Decision making

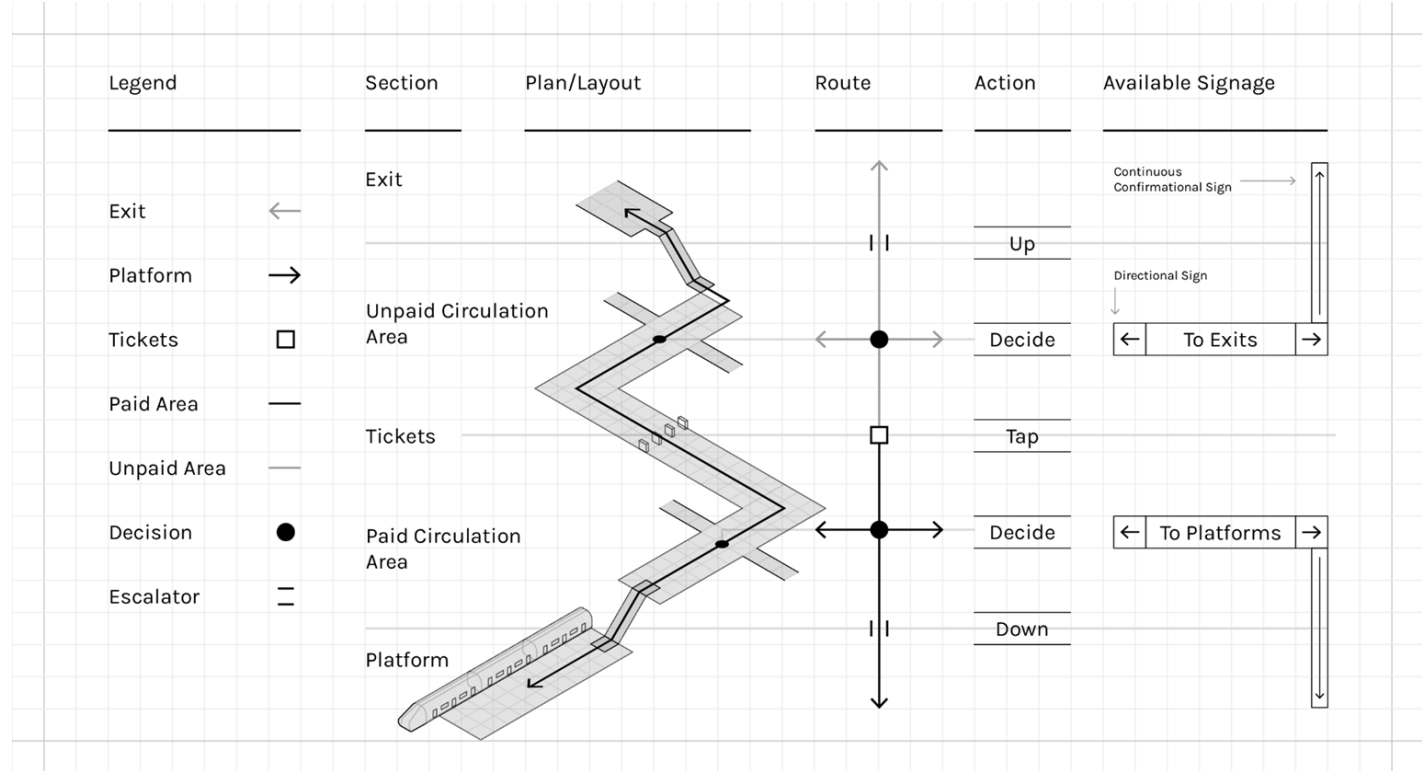

# Wayfinding

## Needs

Simple/Intuitive Directions

Minimal Decision making

Consistency

## Gaps

Lack of Spatial Organisation

Visual Clutter

'Privatised Public Space'

## Proposals

ND Wayfinding Approach

Same route despite Expansion

Minimal Decision making

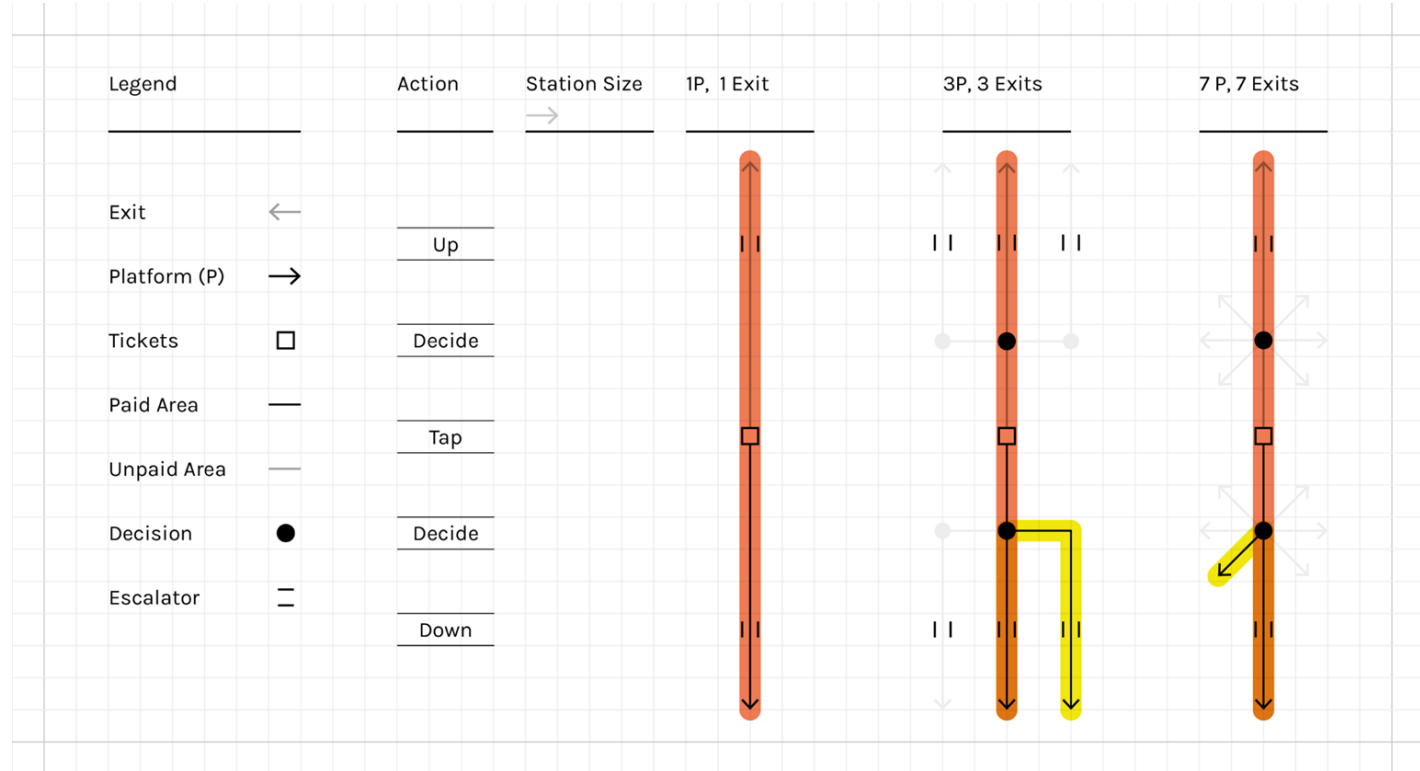

# Wayfinding

## Needs

- Simple/Intuitive Directions
- Minimal Decision making
- Consistency

## Gaps

- Lack of Spatial Organisation
- Visual Clutter
- 'Privatised Public Space'

## Proposals

- ND Wayfinding Approach
- Same route despite Expansion
- Minimal Decision making

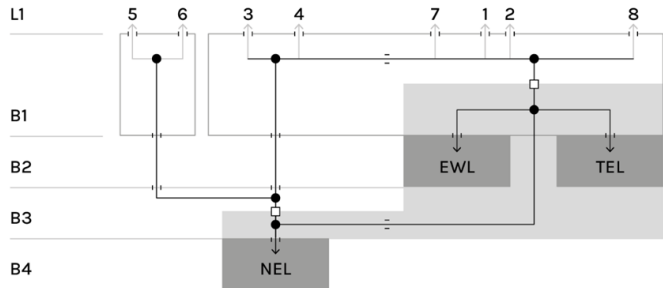
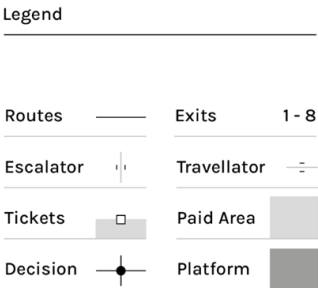
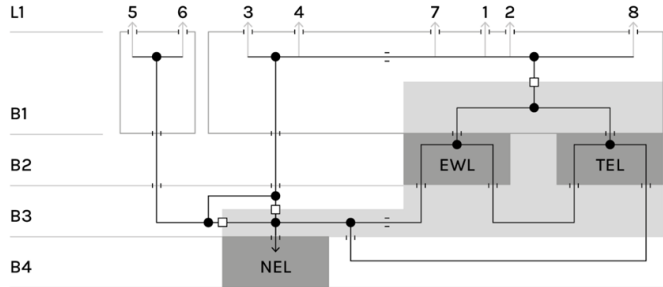
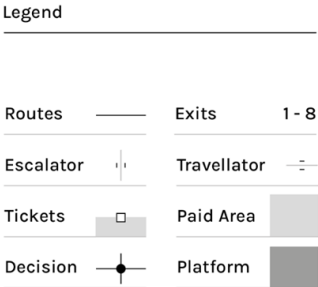

# Social

---

## Needs

---

Privacy & Personal Space

Communication

Retreat Space

## Gaps

---

Seating Arrangement

## Proposals

---

Proxemic Seating

Bus-like Variable Seating

Emergency Retreat Space

# Social

---

## Needs

---

Privacy & Personal Space

Communication

Retreat Space

## Gaps

---

Seating Arrangement

## Proposals

---

Proxemic Seating

Bus-like Variable Seating

Emergency Retreat Space

“

My child is hypersensitive to touch ... he interprets touches as attacks ... won't have a meltdown but might withdraw if there's too much stimulation.

”

# Social

---

## Needs

---

Privacy & Personal Space

Communication

Retreat Space

## Gaps

---

Seating Arrangement

## Proposals

---

Proxemic Seating

Bus-like Variable Seating

Emergency Retreat Space

“

He wants things to be easy enough to figure out on his own so that he doesn't have to ask (strangers) as talking to other people is scary to him

”

# Social

---

## Needs

---

Privacy & Personal Space

Communication

Retreat Space

## Gaps

---

Seating Arrangement

## Proposals

---

Proxemic Seating

Bus-like Variable Seating

Emergency Retreat Space

“

When my child is having an episode, I need to have someplace I can go where I feel safe .. where I can regulate their emotions and calm them down

“

It has to be away from others ... the objective is to be away from the crowd, not exactly on the platform

# Social

## Needs

Privacy & Personal Space

Communication

Retreat Space

## Gaps

Seating Arrangement

## Proposals

Proxemic Seating

Bus-like Variable Seating

Emergency Retreat Space

The Regular  
Carriage

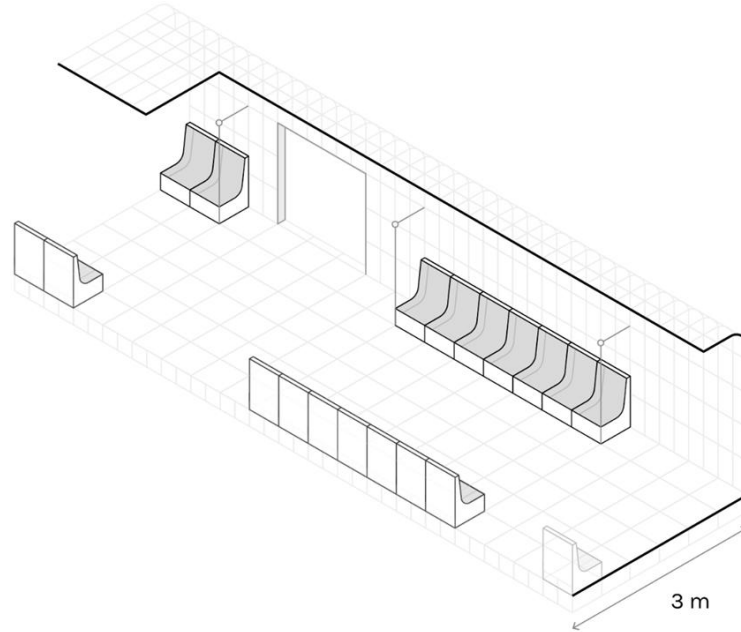

# Social



## Needs

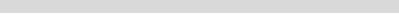

Privacy & Personal Space

Communication

Retreat Space

## Gaps

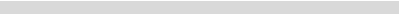

Seating Arrangement

## Proposals



Proxemic Seating

Bus-like Variable Seating

Emergency Retreat Space

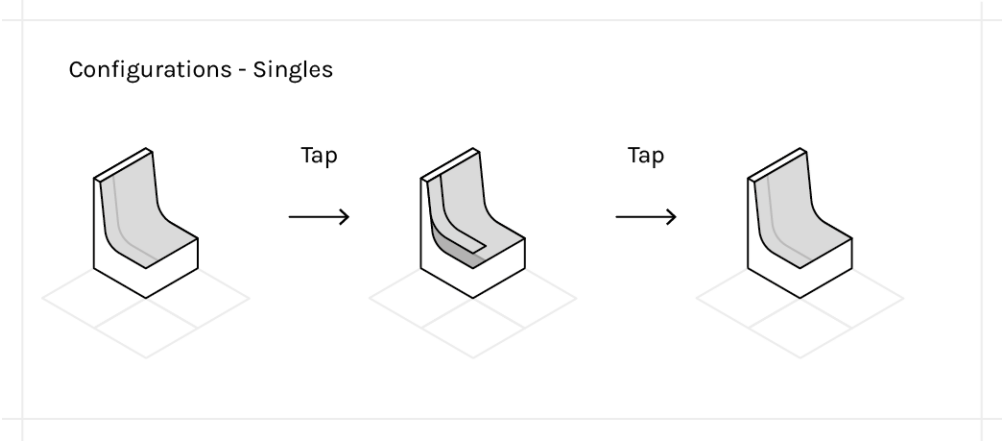

# Social

## Needs

Privacy & Personal Space

Communication

Retreat Space

## Gaps

Seating Arrangement

## Proposals

Proxemic Seating

Bus-like Variable Seating

Emergency Retreat Space

### Configurations - Paired Seats

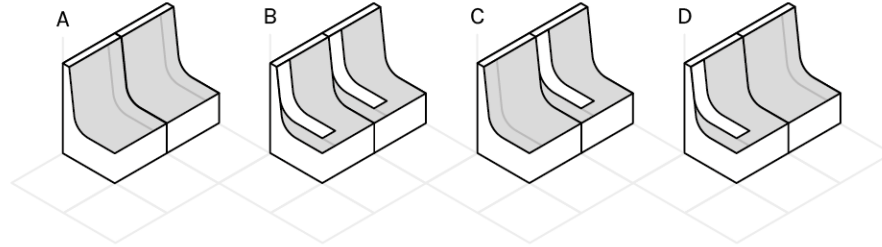

### Configurations - Multiple

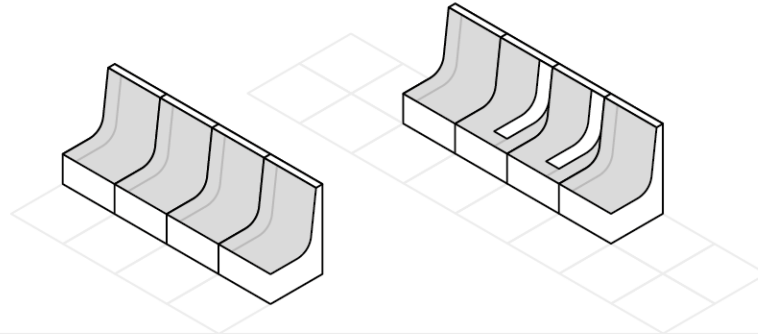

# Social

## Needs

Privacy & Personal Space

Communication

Retreat Space

## Gaps

Seating Arrangement

## Proposals

Proxemic Seating

Bus-like Variable Seating

Emergency Retreat Space

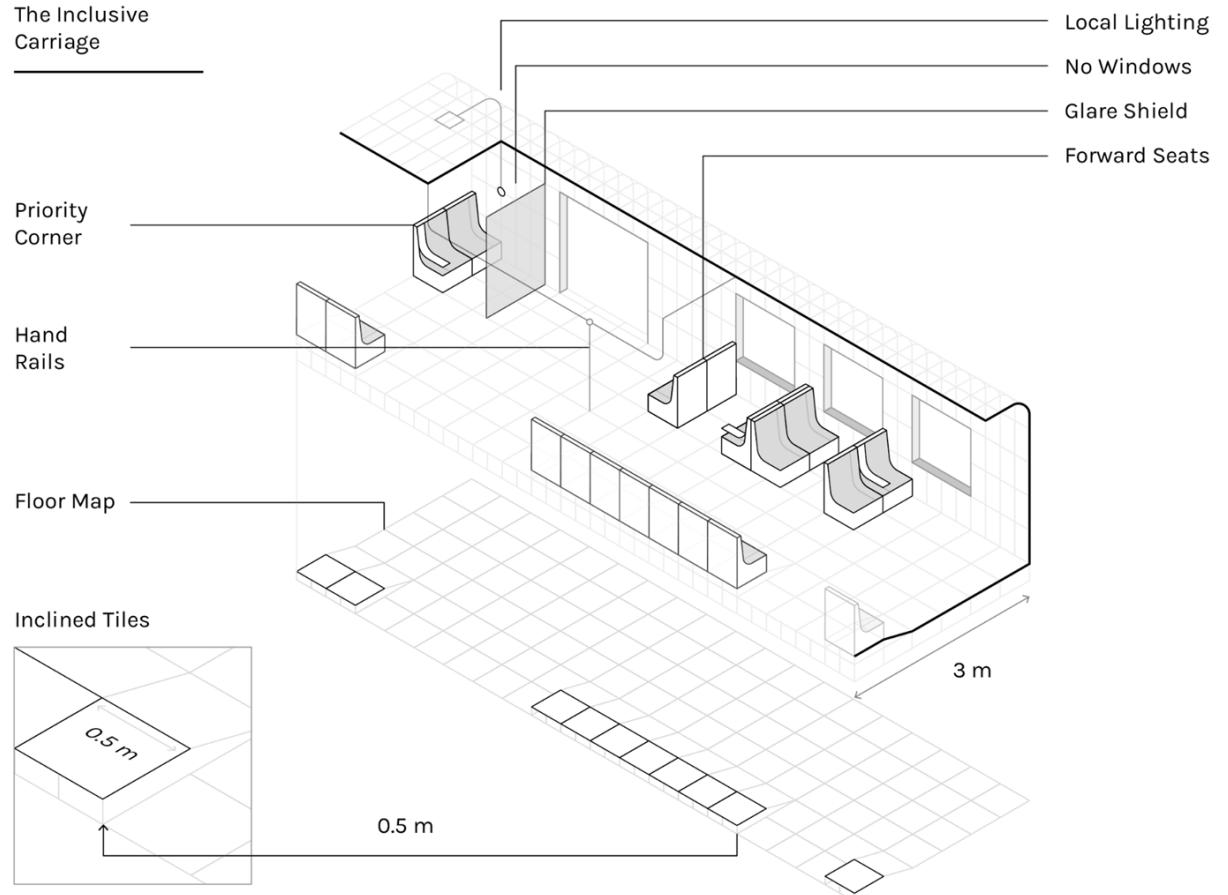

# Social

## Needs

Privacy & Personal Space

Communication

Retreat Space

## Gaps

Seating Arrangement

## Proposals

Proxemic Seating

Bus-like Variable Seating

Emergency Retreat Space

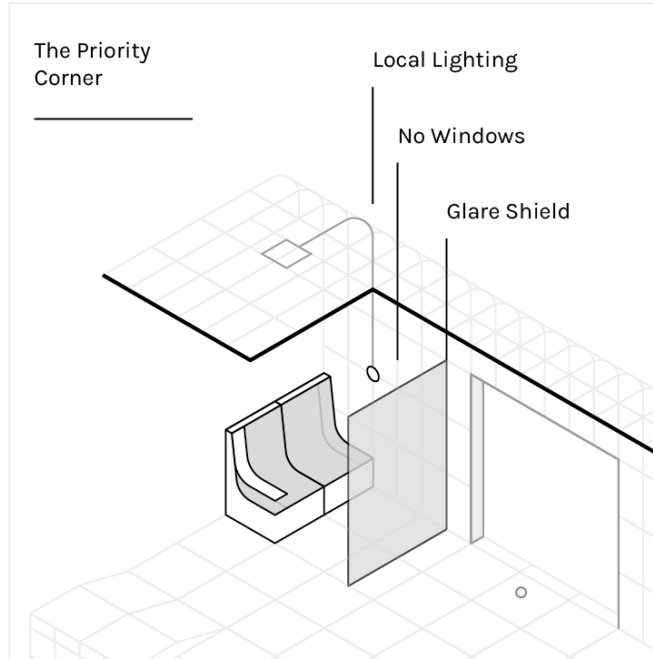

# Social

## Needs

Privacy & Personal Space

Communication

Retreat Space

## Gaps

Seating Arrangement

## Proposals

Proxemic Seating

Bus-like Variable Seating

Emergency Retreat Space

### Legend

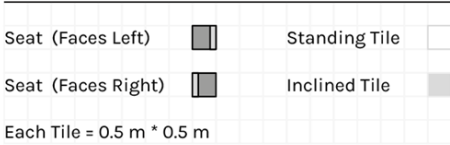

### Plan (Current Layout)

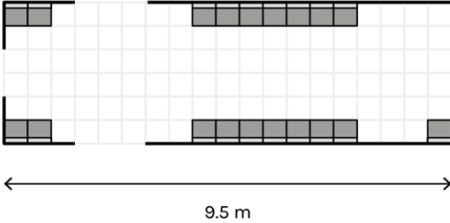

3 m

### Plan (Hybrid Layout)



### Plan (Inclusive Layout)

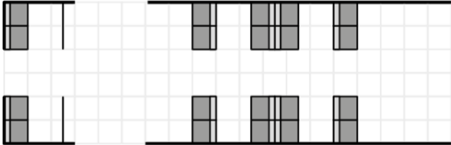

# Social

## Needs

- Privacy & Personal Space
- Communication
- Retreat Space

## Gaps

- Seating Arrangement

## Proposals

- Proxemic Seating
- Bus-like Variable Seating
- Emergency Retreat Space

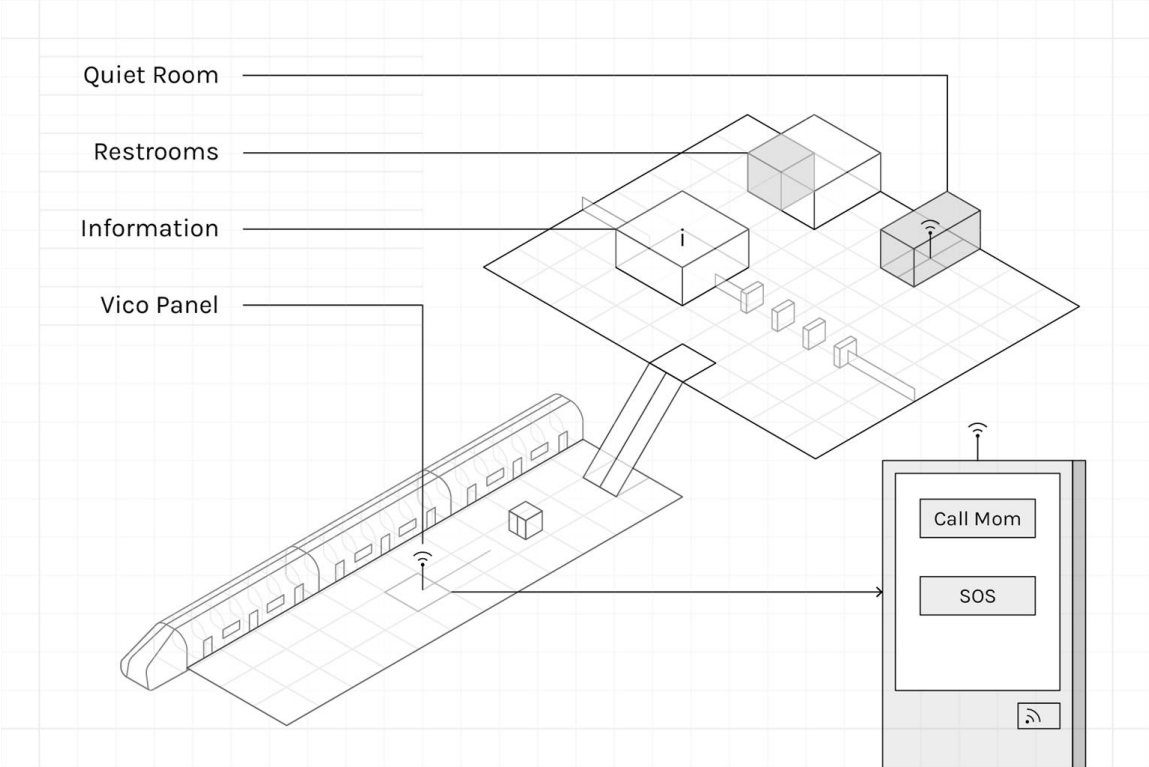

## Next Steps



Advocacy

Translation

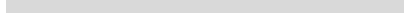
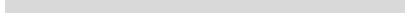

# Next Steps



## Advocacy



Presented to LTA (02/25)  
Singapore Design Week 2023  
WCDH 2025

## Translation



AI X Human-centered Care  
Intelligent Environments



# Next Steps

## Advocacy

Presented to LTA (02/25)

Singapore Design Week 2023

WCDH 2025

## ▶ Translation

Human-AI Collaboration

Intelligent Inclusive Spaces

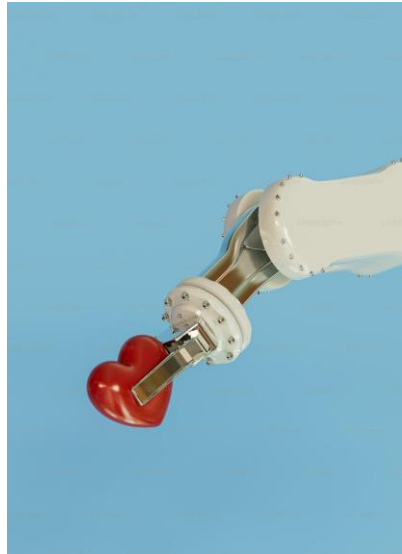

# Conclusion

Neurodiversity & The City

Towards an Accessible World

# Conclusion

Neurodiversity & The City

Towards an Accessible World



# Conclusion

Neurodiversity & The City

Towards an Accessible World

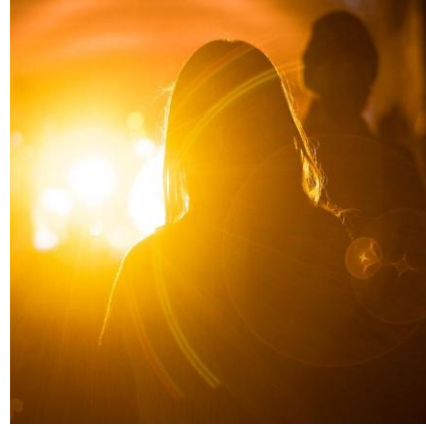

# Conclusion

Neurodiversity & The City

Towards an Accessible World

Legend

---

 Inclusive

 Not Inclusive

 Transport

The City

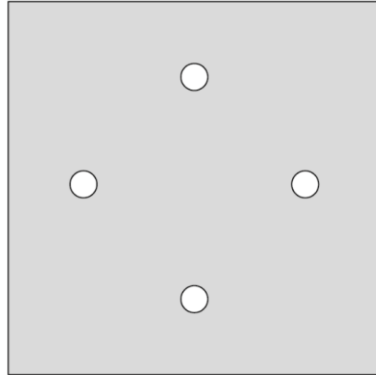

# Conclusion

Neurodiversity & The City

Towards an Accessible World

Legend

---

 Inclusive

 Not Inclusive

 Transport

The City

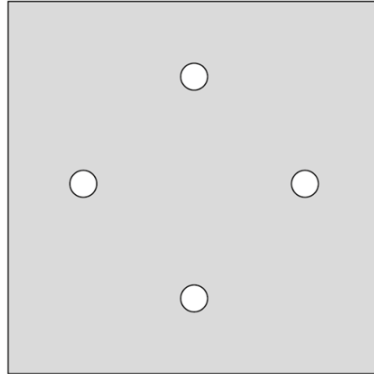

The City

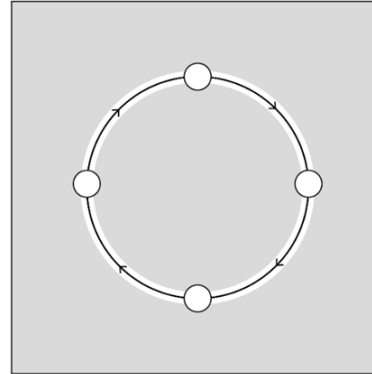

# Conclusion



Neurodiversity & The City

➤ Towards an Accessible World

“

What does inclusive salutogenic design look like? How can we design spaces that not only accommodate neurodivergent people, but help them flourish?

”

# The End



[ishmam.ahmed@aya.yale.edu](mailto:ishmam.ahmed@aya.yale.edu)